

SNITT A-A

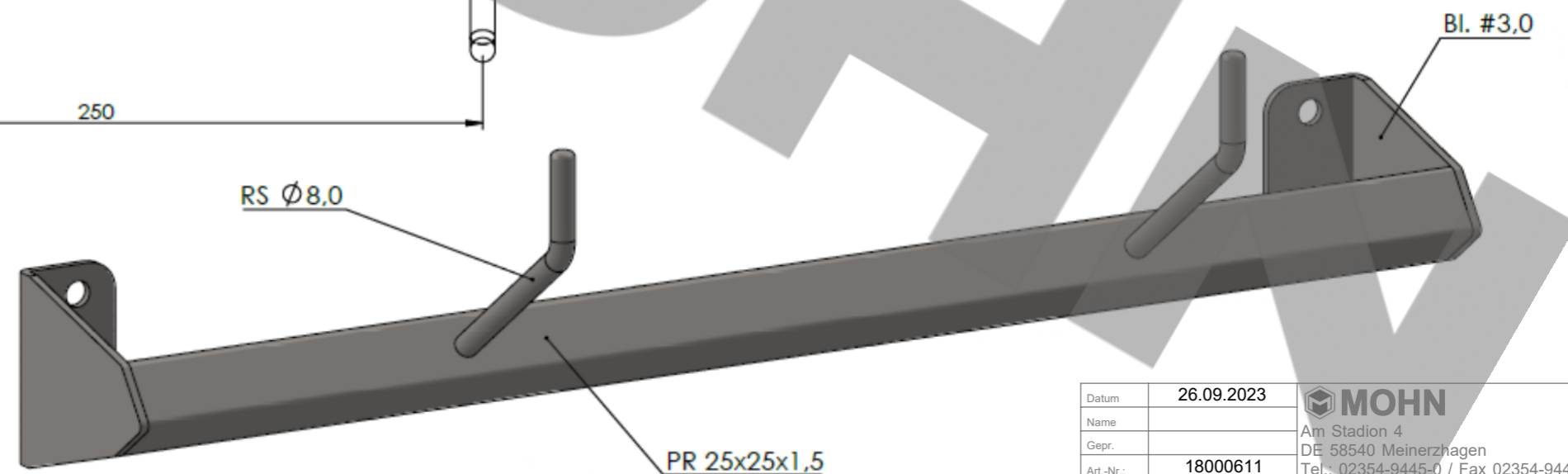

| | | |
|-----------|------------|--|
| Datum | 26.09.2023 | Am Stadion 4 DE 58540 Meinerzhagen Tel.: 02354-9445-0 / Fax 02354-9445-299 www.mohn-gmbh.com / info@mohn-gmbh.com |
| Name | | |
| Gepr. | | |
| Art.-Nr.: | 18000611 | |
| | | Schutzhelm-Hakenleiste, Typ S-HL-2 |
| | | Seite A Z.-Nr.: 13-3647.2 |
| | | Skala: 1:2 Gewicht: kg (+/-10%) Seite 1 von 1 |